

Assembly Instructions



Features

- Replaces existing GO jacks
- 4500 lb dynamic static capacity
- Improved stability
- Easy operation
- Fine leveling capability
- Rapid activation of up/down
- Corrosion resistant finish
- Optional C-Jack Base Pads

SMOOTH OPERATOR™ GO STABILIZER JACK CONVERSION KIT

PARTS LIST:

PART NO.	QTY.	DESCRIPTION
00168-01	4	BAL C-JACKS - 17" EXTENSION
00282-01	2	FRONT BRACKET - MOUNTS BAL C-JACKS TO FRONT OF GO
00282-02	2	REAR BRACKET - MOUNTS BAL C-JACKS TO REAR OF GO
00351-02	8	LARGE HEX BOLT - M10-1.5 X 25mm, 10.9
00377-02	8	LARGE NUT, FLANGED - SERRATED, FLANGED, M10
00368-03	12	HEX BOLT - M8-1.5 X 20mm
00393-03	24	WASHER - FLAT, M8
00394-03	12	LOCK WASHER - LOCK, M8
00377-01	12	NUT, FLANGED - SERRATED, FLANGED, M8
20094-01	1	CRANK HANDLE - HEX DRIVE



OVERVIEW

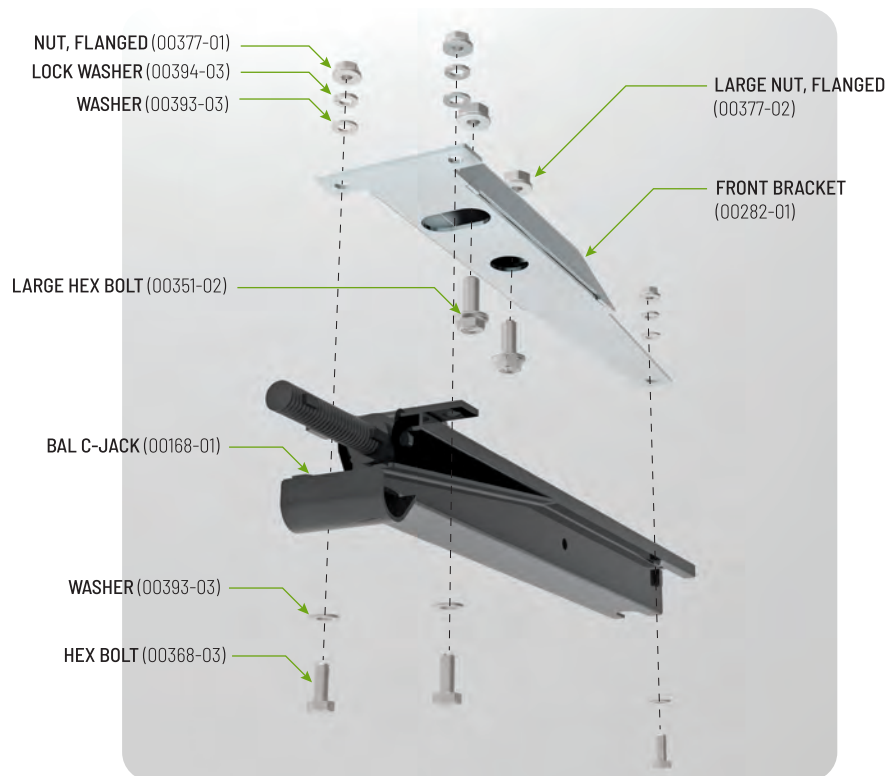

FRONT BRACKET ASSEMBLY

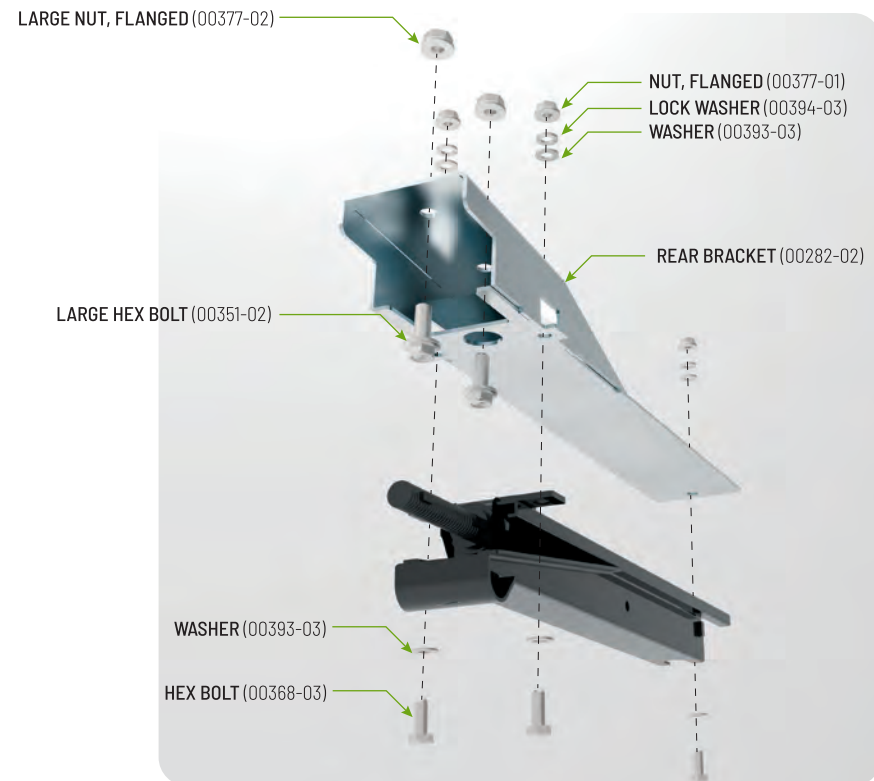

REAR BRACKET ASSEMBLY

SMOOTH OPERATOR™ GO STABILIZER JACK CONVERSION KIT

1. REVIEW PARTS AND OVERVIEW:

Check the contents of your kit and make sure all parts have arrived and are in satisfactory condition. The Overview on page one should provide an understanding of the basic assembly method.

2. REMOVE EXISTING GO JACKS:

Unfasten existing GO Jacks and discard. Older jacks are likely to have fasteners that are difficult to remove. It is helpful to use a penetrating lubricant such as PB Blaster or Liquid Wrench.

3. LOCATE MOUNTING HOLES AND CLEAN AREA:

Referencing the illustration below, locate the mounting hole locations in the GO frame, for each of the BAL C-Jack assemblies. These will use the same holes as the previous jacks that you removed. Clean the surface area you will be mounting to.

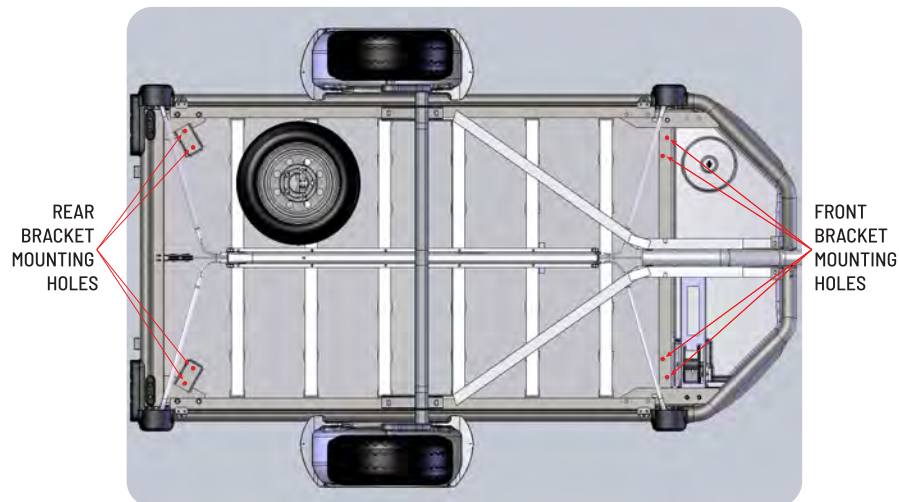

Mounting hole locations

4. FASTEN FRONT BRACKETS TO GO FRAME:

Position the Front Bracket as shown in illustration below. Using a 17mm socket and a 17mm (or adjustable) wrench, secure the Large Hex Bolts (M10) and the Large Nuts, Flanged (M10). Secure the Front Bracket to the GO Frame. Repeat this step on the other (front) side. Tighten bolts securely.



Front Bracket location



Rear Bracket location

5. FASTEN REAR BRACKETS TO GO FRAME:

Position the Rear Bracket as shown in illustration above. Using a 17mm socket and a 17mm (or adjustable) wrench, secure the Large Hex Bolts (M10) and the Large Nuts, Flanged (M10). Secure the Rear Bracket to the GO Frame. Repeat this step on the other (rear) side. Tighten bolts securely.

6. PREPARATION FOR FRONT AND REAR JACK ASSEMBLIES:

Before assembling the two front and two Rear Jack assemblies be sure you have all your hardware organized: (4) BAL Jacks, (12) M8 Hex Bolts, (24) M8 Flat Washers, (12) M8 Lock Washers and (12) M8 Nuts flanged. You will need a 13mm socket and 13mm (or adjustable) wrench to tighten fasteners and secure into position.

7. ASSEMBLE JACKS TO THE FRONT BRACKETS:

Using the 13mm socket and 13mm (or adjustable) wrench, assemble the hardware (identified in Step 6) and the BAL C-Jacks to the Front Brackets, as shown in the illustration below.



Front Jack assembly

8. ASSEMBLE JACKS TO THE REAR BRACKETS:

Using the 13mm socket and 13mm (or adjustable) wrench, assemble the hardware (identified in Step 6) and the BAL C-Jacks to the Front Brackets, as shown in the illustration below.



Rear Jack assembly

NOTE: Optional C-Jack Basepads are available for 17" BAL C-Jacks, at sylvansport.com



SYLVANSPORT®

SMOOTH OPERATOR™
GO STABILIZER JACK CONVERSION KIT

CUSTOMER SERVICE CONTACTS:

SYLVANSPORT.COM

PHONE: 828.393.4927

EMAIL: SUPPORT@SYLVANSPORT.COM

